



电控箱空气调节机

使用手册

沈阳腾飞伟业科技有限公司

Shenyang Tengfei Weiye Technology Co. Ltd.

目 录

- 1- 一般信息
 - 1.1 质量保证
 - 1.2 开箱
 - 1.3 符合标准
 - 1.4 安全注意事项
- 2- 简介
 - 2.1 产品概述
 - 2.2 产品性能参数
- 3- 安装与运转
 - 3.1 地点要求
 - 3.2 电源
 - 3.3 机械安装
 - 3.4 电器安装
 - 3.5 运转启动
 - 3.6 温度设定与调整
- 4- 维护和保养
 - 4.1 清洁
 - 4.2 长时间停止运转
- 5- 故障维修
 - 5.1 设备不运转
 - 5.2 不制冷或制冷不足
- 6- 维修及技术支持
 - 6.1 电路图

1. 一般信息

1.1 质量保证

感谢您购买我公司的机柜用空气调节机。我们深信它会长期为您服务。我们为您提供如下质量保证：

在质保期内（质保期为一年），本产品出现的任何质量问题，都由本公司选择进行修理或更换。在更换情况下，更换部件的质保期为 90 天或者设备整机质保期的剩余天数，以较长的为准。本产品必须退货时，产品应运送到指定的服务中心并预付运输费。在退回货物中应附关于质量问题的详细说明。

如果质量问题是由意外事件、疏忽、不合理的使用、不适当的维修或其它原因导致的，并非由于材料或制造工艺的缺陷引起的，则本保证不适用。对于超出本质量保证期限或范围的情况本保证不适用。

本保证限于中国境内。

1.2 开箱

您所购买的产品是以专用的纸箱和木箱组合装运的，拆除包装时，先将包装外部的打包带拆除，打开木箱然后在将木箱内的纸箱打开并将产品由纸箱内抽出。在产品全部安装完毕并且正常工作之前，请保留木箱和所有包装材料。请立即装配并运行产品以确认其能正常工作。

注意：

- 1、打开产品包装后请及时清点包装内的装箱清单和附件。
- 2、拆除外部包装后，请仔细检查产品外观是否有损伤或者油污。如果发现任何损伤，请在一周内通知我公司并说明产品规格型号及出厂日期。
- 3、为了保护环境，我们建议对包装箱进行回收利用。

1.3 符合标准

表 I 产品适用的标准

标准	标准描述
GB/T17626.7-1998	电磁兼容性
GB4706.1	家用类似用途电器安全
GB4798.1	电工电子产品应用环境条件-储存
GB4798.2	电工电子产品应用环境条件-运输
GB4798.3	电工电子产品应用环境条件-使用

1.4 安全注意事项

1、安装或运转前请先详细阅读本使用手册并注意本手册所提出的注意事项以防止人员或产品损坏。

2、请勿用湿手操作，以免引起触电事故。

- 3、清扫或维修时，请将所有电源切除，以防触电或受伤。
- 4、产品上请勿放置物品，以免坠落造成人员受伤。
- 5、请勿以手指、棒等伸入进、出风口，避免被内部的高速风扇或翅片伤害。
- 6、请确保安装好空气过滤网，以避免冷凝器翅片被脏堵。
- 7、本产品为工业用设备，请勿使用于动植物或食物等方面特殊用途。
- 8、请勿在产品附近放置易燃性液、气体或以易燃性液、气体直接喷洒在产品机体上以防火灾。
- 9、产品禁止用水冲洗，以免引发触电伤害事故或产品故障。
- 10、绝对禁止自行改装、修理、拆卸。要进行上诉动作前请先向专业人员咨询，以防意外。

	这个符号标示本说明手册中与安全特别有关的章节，附在设备上的符号是提醒对有关的操作指南引起注意
---	--

	这个符号指示可能存在危险电压
---	----------------

<p>阅读关于安全、设置和操作的所有说明。 正确操作是用户的责任。</p>

2. 简介

2.1 产品概述

本产品是专门针对机柜等应用环境而开发的一款制冷产品。适用于机柜内部设备发热量较大，内部设备对于环境温度敏感，且内外需要完全隔离的应用场所。本产品可靠性高，安装简单便捷，通电后即可工作，无需复杂调试。

空调器内循环的风路从上部吸入热空气，冷空气从下部排出空调器。外部循环从下部吸入外界冷空气，经过热交换后热空气从上部排出空调器。具体形式见图 I



图 I 产品制冷循环示意图

2.2 产品性能参数

表 II 产品性能参数

项目/型号	TCA-03	TCA-05	TCA-08	TCA-10	TCA-15	TCA-20	TCA-25	TCA-32
制冷能力 (W)	300	500	800	1000	1500	2000	2500	3200
电源	AC 1 P 220 V 50 HZ 其它电源制式订货时特殊注明							
额定功率 (W)	280	400	650	670	730	1100	1300	1500
制冷剂	R134a		R22/R134a					
环境温度 (°C)	5-46°C							
外形尺寸 (mm)	460×285 ×160	680×360 ×185	680×360 ×185	800×400 ×200	920×400 ×200	1165×430 ×245	1185×450 ×245	1200×480 ×270
重量 (kg)	15	25	28	35	45	45	50	75

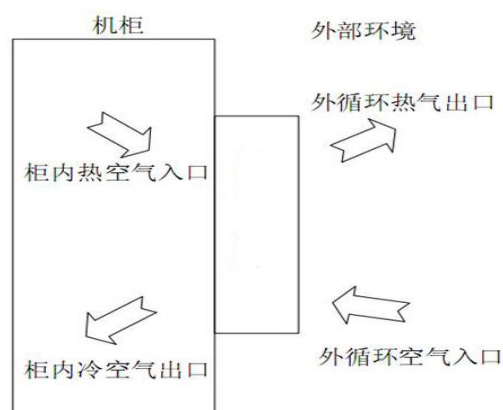
规格可能会修改，恕不另行通知

注：制冷能力是在环境温度 35°C、机柜内温度 35°C 的工况下测定。

3. 安装与运转

	警告：安装前确保所有电源关闭 !!
---	--------------------------

3.1 地点要求

环境温度及相对湿度

我们的产品适合安装在室内，环境温度 10 到 45°C，相对湿度不超过 80% (无凝结)。

位置

- 1、产品周围请勿堆放物品，使四周保持通畅。
- 2、安装在周围空气品质良好场所，请勿安装在有腐蚀性气体、可燃性气体、尘埃、油雾、导电性粉尘（碳粉、金属粉）等空气品质恶劣之场所。
- 3、安装在通风良好且热气容易排放之场所，本产品 and 周围物体间要有至少大于 1 米距离。因本产品在恶劣场所或密闭狭小空间运转时，将使周围温度上升。若冷凝器散热不良，将引起安全阀动作而使产品停止运转。
- 4、请勿将本产品安装在湿度大于 80% 的高湿场所。
- 5、请勿将本产品安装在有震动的场所。
- 6、请选择一个容易保养与清洗滤网的空间安装。
- 7、机柜内零件请勿挡住冷风吹出口，因冷风直接吹零件容易产生结露现象，会造成机柜内原件故障。请尽可能减小机柜内冷风通道阻力，保持畅通。

3.2 电源

应确保空调机的电源连接正确及可靠接地，并确保电压和频率与空调机标牌上所标明的相匹配，电源线要按照电路图的技术要求进行匹配。



警告：请勿带电操作！

3.3 机械安装

空调机机械安装包括如下工作：

- 装排水管
- 在机柜上固定空调

安装工具：10/12 号开口扳手

安装时必须严格按照下述步骤进行：

- 1、清点附件并准备安装工具。
- 2、如果需要安装排水管，将排水管安装在排水嘴处。
- 3、用管箍将排水管可靠固定在排水嘴上，并对接口处进行密封。
- 4、将排水管按照设计的排水路线理顺固定，注意不要扭曲排水管并保持管路畅通。
- 5、用安装螺钉将空调机可靠固定在机柜安装面上。

3.4 电器安装

- 1、电源电压值请保持在容许额定值内，请避免提供电压过高或太低，造成空调机故障。若所提供电压在额定 $\pm 10\%$ 内，本机仍可正常运转。
- 2、电源请接近本空调机，且避免电源线过长。
- 3、请务必使用接地线，本机在配电盘皆有接地线接点，请务必按电器原理图接线。
- 4、电源线/接地线请勿小于指定线径。勿重压、拉扯或加热以防火灾、触电等灾害。
- 5、请自行安装漏电断路器。

3.5 运转启动

- 1、本产品安装完成时，须等 15 分钟后在通电启动，以确保压缩机安全运转。
- 2、运转中要重新开启空调机时，请间隔 3 分钟后在开启。若启动次数频繁且间隔时间太短易造成空调机损坏。
- 3、空调机严禁倾斜使用，以免引起损坏、漏水或触电事故。
- 4、产品启动前请做好配电箱接地工作，并做好排水管路的连接。
- 5、机柜门打开时间请勿运转空调机，以免结露。同时空调机在运转中请勿打开机柜门。
- 6、有异常情况或异味（焦臭）时，请立即停止空调机运转并检查，以防止触电或火灾。



警告：请勿带电操作！

3.6 温度设定与调整

操作指南

📖 面板图:



📌 面板上的指示灯含义是什么?

面板上的指示灯从左到右排列的功能含义如下表:

指示灯	指示灯名称	亮	闪烁
	温度设定	正在温度设置状态	-
	制 冷	正在制冷	准备制冷, 在压缩机延时保护状态
	制 热	正在制热	准备制热, 在压缩机延时保护状态
	-	-	-
	-	-	-
	告 警	-	告警状态

📌 数码管显示含义

数码管在正常时显示温度, 如果显示“SHr”表示温度传感器短路, “OPE”表示温度传感器断线。

告警时交替显示温度和告警代码(Axx)。显示代码如下表:

告警代码	含义	说明
A11	外部告警	来自外部告警信号的告警, 请参见内部参数代码“F50”
A21	温控探头故障	温控探头断线或短路(当前温度显示“SHr”或“OPE”)

🔔 怎样设置温度?

在显示温度状态，长按“Set”键2秒，进入温度设置状态，这时数码显示器上显示的温度即为设定温度，然后用上或下键改变设定值（“▲”键增0.1℃，“▼”键减0.1℃，按住不放超过0.5秒则快速增减）。设置完成后按“Set”键退出设置状态（设置温度范围受参数F13和F14限制，请参见高级设置）。设置过程中按“M”键表示放弃，退出但不保存设置值。

🔔 怎样进行强制冷（或制热）?

在显示温度状态，温度介于“设定温度-温差”和“设定温度+温差”之间时，系统可能制冷也可能不制冷，这时按住“▲”键不放保持5秒，若在制冷模式下，则可以强制启动制冷，当温度低于“设定温度-温差”时，停止制冷；若在制热模式下，则可以强制启动制热，当温度高于“设定温度+温差”时，停止制热。

✓ 高级操作

长按“M”键5秒，进入参数设置状态，如果设置了口令，会显示“PAS”字样提示输入口令，用“▲▼”键输入口令，如果口令正确，则会显示参数代码，用“▲▼”键选择参数代码，选择一个代码后按“Set”键则显示该代码对应的参数值，这时再用“▲▼”键即可对参数值进行设置（按住“▲”或“▼”键不放可连发），设置完成后再按“Set”键，回到显示参数代码状态。在显示参数代码时按“M”键可退出参数设置状态，在设置参数值过程中按“M”键表示放弃，退出但不改变参数值。参数代码如下表所示：

类别	代码	参数名称	设定范围	出厂设定	单位	备注
温控类	F11	设定温度	F14 - F13	33	℃/ °F	设定范围受 F13 和 F14 的限定
	F12	温差	0.1 - 20	3	℃/ °F	控制温度的回差, 详见温度控制原理的说明
	F13	最高设定温度	-58 - 302	35	℃/ °F	注意: 控制器会强制维持 F14<F11<F13 这一规则, 如果发现某一参数不能调整, 是因为被其它参数“顶”住了, 要先调整另一个参数。
	F14	最低设定温度	-58 - 302	25	℃/ °F	
	F19	温控探头修正	-20.0 - 20.0	0.0	℃/ °F	校正温控探头误差
压机类	F21	压缩机停机保护时间	0 -- 10	3	分钟	
	F29	压缩机控制模式 (温控模式)	COOL/HEAT	COOL	-	COOL: 制冷模式 HEAT: 制热模式
告警类	F50	外部告警模式	0 -- 4	0	-	0 : 不使用外部告警 1 : 常开, 不锁定 2 : 常开, 锁定 3 : 常闭, 不锁定 4 : 常闭, 锁定
系统设置类	F80	口令	OFF 0001 -- 9999	OFF	-	OFF 表示无口令 设置成 0000 表示清除口令
	F81	温度单位	C/F	C	-	C: 摄氏 F: 华氏
测试类	F98	厂家保留				
	F99	自检	此功能会依次吸合所有继电器, 严禁在线使用			
	End	退出设置				

4. 维护保养

请定期检查排水管是否确实排水, 若排水不良易造成机柜内漏水。请定期清洗空气过滤网和冷凝器

4.1 清洁

1、请至少每隔 2 周取下空调机下方的空气过滤网, 用喷气枪或清水清洗, 并使过滤网干燥。

2、请按照空调机周围空气洁净程度定期清洗, 以防止冷却效果降低或使空调机产生故障。

3、油气易损害电控系统, 请务必锁紧机柜门。

4、请用中性清洗剂清洁擦拭空调机机体。

5、请勿用水冲洗空调机, 以防触电

沈阳腾飞伟业科技有限公司

8

4.2 长时间停止运转

- 1、本产品若长时间停止使用，请使用灰尘隔离措施。
- 2、请清理易堆积灰尘污垢之部位，如空气过滤网和冷凝器。
- 3、请切断电源以防意外。

5. 故障维修



警告：维修应由有维修工作资质证的人员进行，电源接通时，控制箱部分会有危险电压存在。带电测量电压必须倍加小心!!!

5.1 机器不运转

- 检查电源线是否连接好.
- 检查电源开关是否开启.

5.2 无制冷或制冷不足

- 检查是否电压太低或太高.
- 检查通风处是否有堵塞.
- 检查环境温度，过高的环境温度会引起制冷压缩机短时停机.
- 检查是否过多的热量被转移到控制柜里，因为这会超过制冷系统的冷却能力.

6. 维修及技术支持

如果你遵照第 5 章列出的步骤进行了故障诊断与处理，空调机还不能正常工作，请与生产厂家取得联系，并为维修工程师提供如下信息：

- 型号、出厂日期
- 购买日期
- 设备问题

6.1 电路图

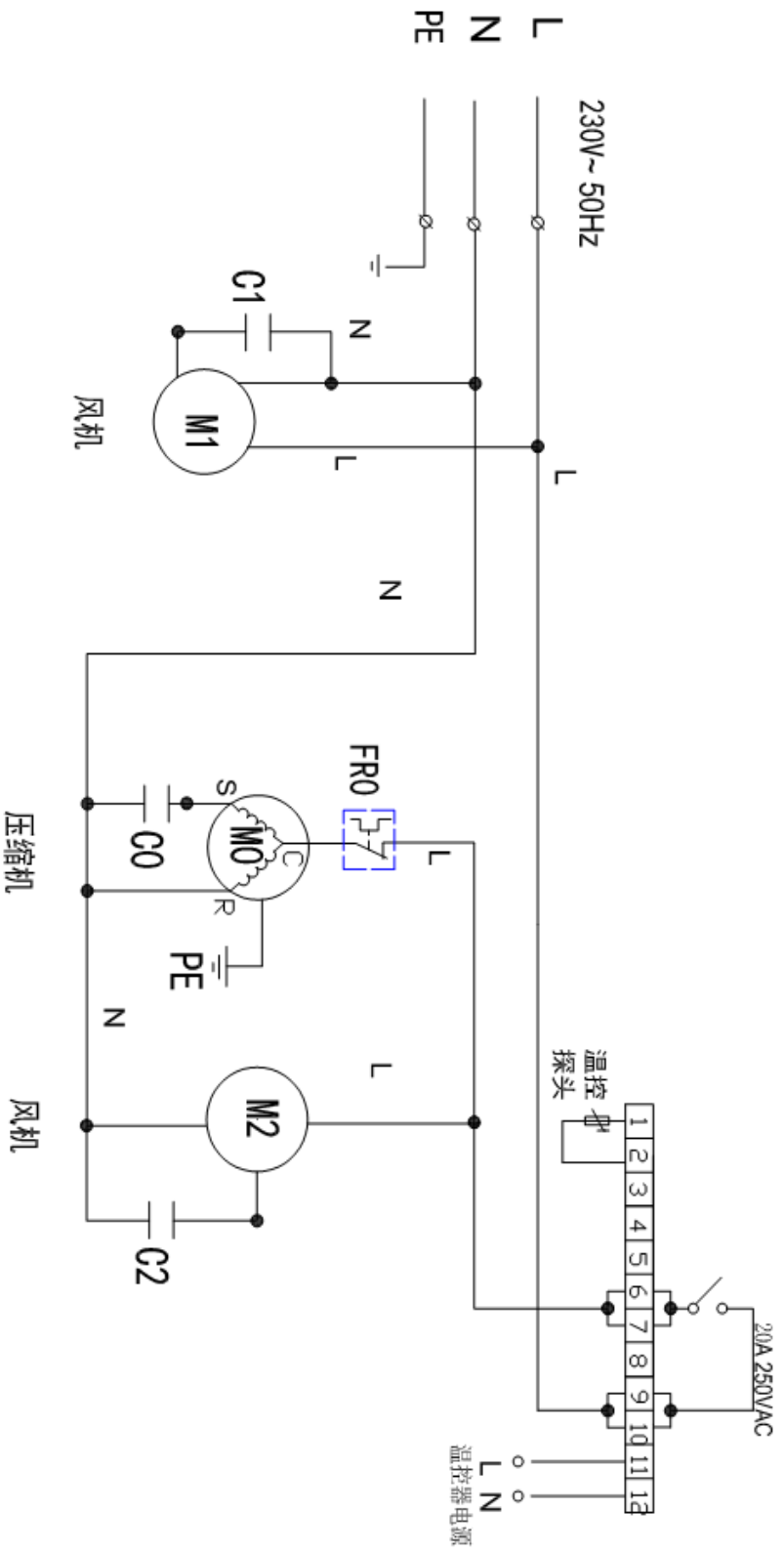

Catalogue

- 1 General Information
 - 1.1 Quality Assurance
 - 1.2 Unpacking
 - 1.3 Standards Compliant
 - 1.4 Safety Precautions

- 2 Introduction
 - 2.1 Product Profile
 - 2.2 Product Performance

- 3 Installation and operation
 - 3.1 Location Requirement
 - 3.2 Power Source
 - 3.3 Machinery Installation
 - 3.4 Electrical Installation
 - 3.5 Start and Run
 - 3.6 Temperature setting and adjustment

- 4 Maintenance
 - 4.1 Cleaning
 - 4.2 Long time to stop running

- 5 Breakdown maintenance
 - 5.1 The machine does not spin
 - 5.2 No cooling or insufficient refrigeration.

- 6 Maintenance and technical support
 - 6.1 Circuit diagram

1 General Information

1.1 Quality Assurance

Thank you for purchasing our mca electricity gas tank air conditioning. We are confident that it will serve you for a long time. We offer you the following quality assurance:

Within the warranty period (warranty period is one year), any problems of the product will be repaired or replaced by the company. In case of the placement, the period for the remaining days of the 90 days or equipment machine warranty period based on the longer prevail. If the product must be returned, it should be shipped to the designated service center and transportation prepaid. Returned goods shall be accompanied by a detailed description of the quality problems.

If quality problems by accident, neglect, unreasonable use, improper maintenance or other reasons lead, not due to material or workmanship defect, this guarantee does not apply. For beyond the quality warranty, the permit duration or scope of the situation this warranty does not apply.

This warranty is limited to the territory of China.

1.2 Unpacking

The product you buy is in special cartons and crates combination shipment, the package has been removed, the first packaged with the dismantling of the outside of the package, open the wooden box and then in the wooden box inside the cardboard box open and products from out of the carton. All products installed and working properly before the wooden box and all packaging materials reserved. Immediately assembled and run the product to confirm its normal work.

Pay attention:

- 1、 Please kindly check the packing list and accessories when you open the package.
- 2、 Please carefully check if there is damage or oil in the appearance of the products after you remove the external package. If any damage be found, please contact us within one week and notify the description of the product specifications and encodings.
- 3、 We recommend that recycling the box in order to protect the environment.

1.3 Standards Compliant

Standards	Description of Standards
GB/T17626.7-1998	Electromagnetic Compatibility
GB4706.1	Home similar electrical safety
GB4798.1	Application of environmental conditions of electric and electronic products-Storage
GB4798.2	Application of environmental conditions of electric and electronic products-Transportation
GB4798.3	Application of environmental conditions of electric and electronic products-Usage

1.4 Safety Precautions

- 1、 Please read the user manual and pay more attention to the safety precaution to prevent personal or damage to the product before installation and operation.
- 2、 Do not operate with wet hands so as not to cause an electric shock.
- 3、 Please keep all power excision to prevent electric shock or injury when cleaning or maintenance.
- 4、 Please do not place items on the products so as not to fall, causing personal injury.
- 5、 Do not use your fingers, rods extend into the outlet to avoid internal high-speed fan or fin damage.
- 6、 Be sure to install a good air filter, in order to avoid the heat exchanger fins are dirty block.
- 7、 The products for industrial equipment, please do not use for special purposes such as plants, animals or food.
- 8、 Do not be placed flammable liquid, gas or flammable liquid near the products, gas sprayed directly in the product on the body to prevent fire.
- 9、 Forbidding water rinse, so as not to cause an electrical shock accident or product failure.
- 10、 Prohibited to make alterations, repairs, demolition absolutely. Please consulting professionals to prevent accidents before you appeal actions.



This symbol mark with special reference to the Security section in this instruction manual, attached to the equipment of the symbol is to alert the relevant operating instructions attention



This symbol indicates a potentially dangerous voltage

Read all instructions on safety, set up and operate.
Proper operation is the responsibility of the user.

2 Introduction

2.1 Product Profile

This product is a cooling products developed specifically for the cabinets, and other application environments. Applicable to the larger the cabinet internal equipment heat, the internal device is sensitive to the ambient temperature, and the inside and outside completely isolated application spaces. The high reliability of the product, the installation is simple and convenient, energized to work without the need for complex debugging.

Circulating in the mca electricity gas tanik air conditioning inside the air passage from the lower suction hot air, cold air is discharged from the upper portion. The external circulation from the upper to inhalation of cold air from the outside, after heat exchange hot air discharged from the lower part of the air conditioner. The concrete in **.the form shown in Figure I**

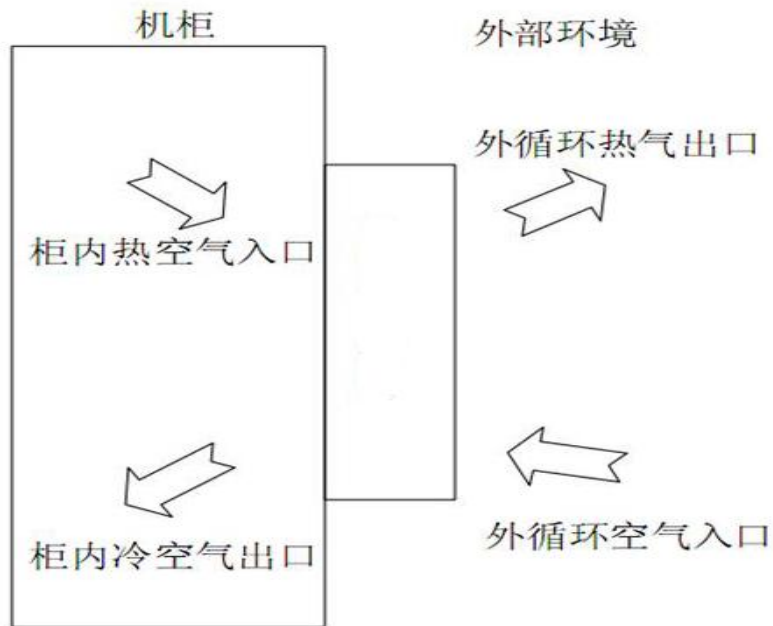

I Diagram for the Product Heat Exchange Loop

2.2 Product Performance

Product Model	TCA-03	TCA-05	TCA-08	TCA-10	TCA-15	TCA-20	TCA-25	TCA-32
Cooling Capacity (W)	300	500	800	1000	1500	2000	2500	3200
Power	AC 1 P 220 V 50 HZ 其它电源制式订货时特殊注明							
Input Power (W)	280	400	650	670	730	1100	1300	1500
Refrigerant	R134a		R22/R134a					
Adapt to the environment (°C)	5-46°C							
Dimensions (mm)	460×285 ×160	680×360 ×185	680×360 ×185	800×400 ×200	920×400 ×200	1165× 430×245	1185× 450×245	1200× 480×270
Overall Weight (kg)	15	25	28	35	45	45	50	75

Specifications may change without prior notice

Remark: The capacity is at ambient temperature of 35 °C, the cabinet temperature of 35 °C operating conditions determination.

3 Installation and operation

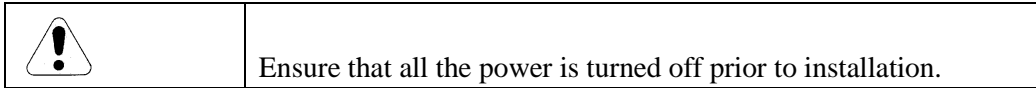

3.1 Location requirements

Ambient temperature and relative humidity

Our products are suitable for installation in indoor ambient temperature of 10 to 45 °C, relative humidity not more than 80% (non-condensing).Location

- 1、 Do not stack items near the product to keep them open.
- 2、 Installed in the ambient air quality good places, do not install in corrosive gas, flammable gas, dust, oil mist, conductive dust (toner, metal powder), poor air quality in the workplace.
- 3、 Installed in a well-ventilated place and likely to emit heat, there must be at least greater than 1 m distance between the product and the surrounding objects. Ambient temperature will rise due to the operation of the product in bad places or confined narrow space. Radiator heat is bad, will cause safety valve and the product operation.
- 4、 Do not install this product in humidity greater than 80% of the high humidity places.
- 5、 Do not install this product in the vibration of the place.
- 6、 Please select an easy maintenance and cleaning the screen space installation.
- 7、 machine cabinets parts export, please do not block the cold wind blowing directly from a cold wind blowing parts prone to dewing phenomenon, cause cabinet fault in the original. Please minimize machine cabinets air cooling channel resistance, keep open.

3.2 Power Source

Ensure that the power of the air conditioner is properly connected and reliable grounding, and ensure that the match indicated on the sign of the voltage and frequency of air conditioners, the power line is to be carried out in accordance with the technical requirements of the circuit diagram match.



3.3 Mechanical Installation

Installation of the Air Conditioner including procedures as followings:

- Install drain
- Fix mca electricity gas tank air conditioning cabinet

Tools for Installation: open-end wrench 10/12#

You must be strictly in accordance with the following steps when installing:

- 1、 Check the list and prepare the tools.
- 2、 If need to install a drain, the drain is installed in the mouth.
- 3、 With a pipe hoop will drain reliable fixed in drainage mouth, and the joints are sealed.
- 4、 Will drain according to drainage design of fixed, and be careful not to distort the drain and keep open lines.
- 5、 Firmly secured to in cabinet mounting surface with the mounting screws of the Air Container.

3.4 Electrical Installations

1、 Supply voltage value remains within the allowable rating, avoid the voltage is too high or too low that resulting in heat exchanger failure. If the supplied voltage rated within $\pm 10\%$ of this machine to continue its normal operation.

2、 Please ensure the power supply close to the heat exchanger, and avoid long power cord.

3、 Be sure to use the ground wire, the machine in the distribution panel Jieyou ground wire contact, make sure electrical schematics wiring.

4、 The power cord/ground wires do not less than the specified diameter. Do not stress, pulling, or heating to prevent disasters such as fire, electric shock.

5、 Please install leakage circuit breaker.

3.5 Start and Run

1、 This product installation is complete, you must wait 15 minutes after the power at startup, to ensure the safety of the compressor operation.

2、 Run to open air conditioner, please interval after 3 minutes in the open. If the frequent start times and time interval too short easy to cause damage of air conditioner.

3、 Mca electricity gas tanik air conditioning tilt is forbidden to use, lest cause damage, leaks or get an electric shock accident

4、 Before starting the product, please do a good job in power distribution box of grounding and drain the connection of the road.

5、 Cabinet door open time do not run mca electricity gas tanik air conditioning in order to avoid condensation. At the same time mca electricity gas tanik air conditioning in operation please do not open the cabinet door.

6、 Have abnormal situation or smell (burnt odour), please immediately stop the mca electricity gas tanik air conditioning run and inspection, in order to prevent electric shock or fire.

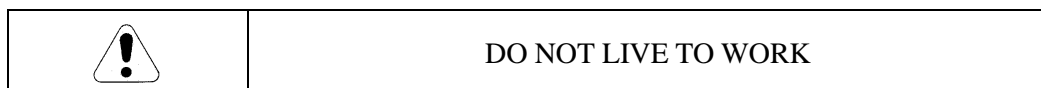

3.6 Temperature setting and adjustment





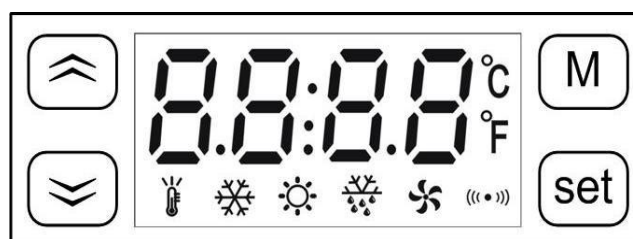

Operating Guide

Panel:



What's the meaning of the index lights on the panel?

The function of the LED on the panel is showing below:

Index Light	Name	Light	Flash
	Temp Setting	In the state of temp setting	-
	Refrigeration	Refrigerating	Ready to refrigerate, in the state of compressor start delay protection
	Heat	Heating	Ready to heat, in the state of compressor start delay protection
	-	-	-
	-	-	-
	Alarm	-	Alarm state

The meaning of the LED display

The LED usually shows temperature, if it shows “SHr”, it means the temperature sensor is short, and “OPE” means the temperature sensor is open. The temperature and the alarm code (Axx) will show alternately when in the alarm state.

The code is showing below:

Code	Signification	Explanation
A11	External alarm	Alarm from external alarm signal, please refer to the internal parameter code “F50”
A21	Temperature sensor error	Open or short (showing “OPE” or “SHr”)

How to set the temperature?

Press the key “set” for at least 2 seconds, then enter the state of temperature setting, here the LED displays the setting temperature, then using “▲” key or “▼” key can change the parameter (the key“▲”adds 0.1°C, the key“▼”minuses 0.1°C, press and hold it over 0.5 seconds can add or minus rapidly) . After setting, press “set” again, then exit the state of parameter setting. (The setting temp range is limited by the parameters F13 and F14, please refer to the advanced operation). Pressing the key “M” in the setting process means cancel and exit, but the setting value will not be saved.

How to refrigerate (or heat) forcibly?

When displaying current temperature, the temperature is between “setting temperature—temperature

difference” and “setting temperature+temperature difference”, the system may or not refrigerate, here you press the key “▲” and hold it for 5 seconds, the controller will enter the refrigeration state forcibly when in the refrigeration state, and stop refrigeration when the temperature is below “setting temperature—temperature difference”; the controller will enter the heat state forcibly when in the heat state, and stop heating when the temperature is above “setting temperature+temperature difference”.

✓ **Advanced Operation**

Press the key “M” and hold it for 5 seconds, and if you have set the password, the LED display the “PAS” to hint you to enter the password, you can use the key “▲” and “▼” to enter the password, if the password is correct, the LED will display the parameter code, use “▲” or “▼” to select the parameter code, Pressing the “set” key can make it to show the value of the parameter after select the parameter, here you use “▲” or “▼” to set the parameter(pressing the key and not release can add or minus rapidly), then press the “set” key to return to the state of showing parameter code after finishing setting. Pressing the key “M” can exit the parameter setting state when display the parameter code, pressing the key “M” means cancel when in the process of setting parameter, and the parameter will not be changed.

Internal parameter code is showing below:

Sort	Code	Parameter Name	Range	Factory setting	Unit	Remark
Temperature	F11	Setting temperature	F14 – F13	33	°C/°F	The setting range is limited by F13 and F14
	F12	Temperature difference	0.1 – 20	3	°C/°F	Control the temperature difference, please refer to the temperature controlling
	F13	Max setting temperature	-58 - 302	35	°C/°F	Notice: the controller will follow the rule of F14<F11<F13 forcibly, if you find out that one parameter can not be adjusted, it is because the parameter is limited by other parameters, you must first adjust other parameters
	F14	Min setting temperature	-58 – 302	25	°C/°F	
	F19	Temp sensor adjustment	-20 – 20	0.0	°C/°F	Adjust the temperature sensor bias
Compressor	F21	Compressor delay time	0 -- 10	3	min	
	F29	Compressor controlling mode (temp controlling mode)	COOL / HEAT	COOL	-	COOL: refrigeration mode HEAT: Heat mode
Alarm	F50	External alarm mode	0 -- 4	0	-	0: without external alarm 1: always open, unlocked 2: always open, locked 3: always closed, unlocked 4: always closed, locked
System setting	F80	Password	OFF 0001 -- 9999	OFF	-	OFF means no password 0000 means clearing password
	F81	Temperature unit	C/F	C	-	C: Centigrade F: Fahrenheit
Testing	F98	Reserved				
	F99	Test self				This function can attract all relays in turn, and please don't use it when the controller is running!
	End	Exit				

4. Maintenance

Please check the drain is indeed drainage, if drainage is undesirable machine cabinets isleaking.

Please regular cleaning the air filter and the condenser.

4.1 Cleaning

1. Remove the mca electricity gas tank air conditioning at the top of the air filter cleaning and filter dry with air gun or water at least every two weeks.

2. Follow the cleanliness of air around the heat exchanger cleaning on a regular basis, in order to prevent heat exchange efficiency is reduced or the heat exchanger fails.
3. Be sure to lock the door as the electric control system of oil and gas is easy to damage.
4. Clean mca electricity gas tanik air conditioning with a neutral cleaning agent to clean the unit.
5. Do not rinse the mca electricity gas tanik air conditioning to prevent electric shock.

4.2 Long time to stop running

1. If long time stop using this product, please use the dust of segregation.
2. Please clean up the sites of the easy accumulation of dust, dirt, air filters and condenser
3. Please cut off the power supply to prevent accidents.

5. Maintenance

	<p>Warning: repairs should be carried out by servicing certificates of qualification personnel, the power supply is switched on, and the control box part is the presence of dangerous voltage. Live line measurement of voltage must be careful!!!</p>
---	---

5.1 Machine does not spin

- Check that the power cable is connected properly.
- Check that the power switch is turned on.

5.2. No cooling or insufficient retrigger

- Check whether the voltage is too low or too high.
- Check that the ventilation is blocked.
- Check the environment temperature, high temperature can cause compressor short downtime.
- Check if excessive heat is transferred to the control cabinet, as this will over heat the system's heat capacity.

6. Maintenance and technical support

If you follow the 5th chapter lists steps for fault diagnosis and treatment, heat exchangers also do not work, please get in touch with manufactures and maintenance engineers to provide the following information:

- Models, factory codes
- Date of purchase
- Device problem

6.1 Circuit diagram

